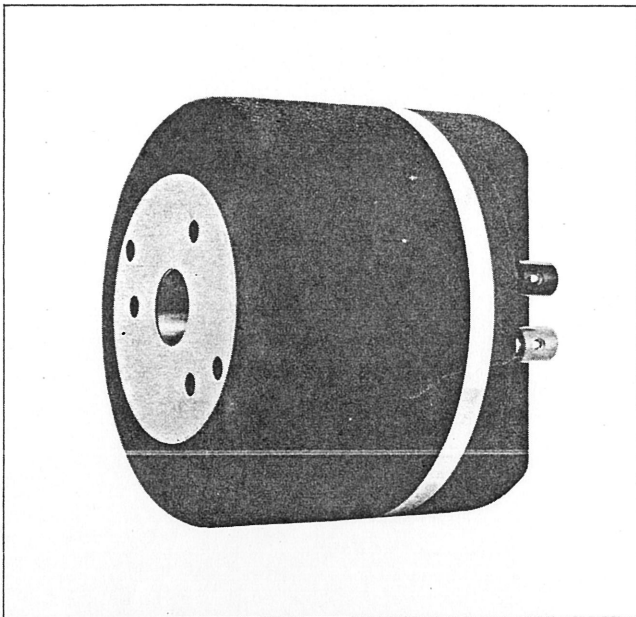

**INSTRUCTION MANUAL****SPECIFICATIONS**

Voice coil impedance . . . . .	8 ohms
Frequency response . . . . .	500~22,000Hz (when 250Hz cut-off radial horn mounted)
Voice coil diameter . . . . .	2 in (48mm)
Equalization System . . . . .	Triple-slit rear type
Throat connection diameter . . . . .	1 in (25.4mm)
Mounting pitch . . . . .	3 in (76.2mm) (for 2 holes) 2-1/4 in (57.2mm) (for 3 holes)
Rated input . . . . .	10W } For crossover frequency
Musical program input . . . . .	40W } of 800Hz, -12dB/oct.
Output sound pressure level . . . . .	109dB/W [Measured at 1m on axis from mouth of 90° radial horn (Depth 470mm)]
Crossover frequency . . . . .	800Hz or higher (-12dB/oct)
Total magnetic flux . . . . .	68,500Mx
Magnetic flux density . . . . .	18,000G
Dimensions (diam. x depth) . . . . .	5-9/16x4-3/16 in (141x107mm)
Weight . . . . .	14 lb 2 oz (6.4kg)
Accessories . . . . .	Hexagonal bolts (M6x15) x 3, Flat washers x 3, Spanner x 1, Instruction manual x 1

*\* Specifications and features are subject to change without notice.*

**FEATURES****Pure Beryllium Diaphragm**

The TD-2001 high frequency driver features a 48mm diameter beryllium diaphragm engineered to a very high degree of purity by unique vacuum evaporation techniques. Beryllium is known as one of the most rigid, yet lightweight, of all the metals. Transmission of sound waves is also among the most rapid, making this material ideal for use in high frequency speaker units. The diaphragm of the TD-2001 weighs no more than 0.13g, and the frequency response is extremely flat with the high range resonance frequencies extending beyond the audible frequency limit. Outstanding definition and transient response are also obtained. Furthermore, the high molecular compound material used in the roll edge eliminates the lateral vibration at the low to mid-range frequencies, and also prevents fatigue and rupture caused by large amplitude signals.

**Rear Compression**

The TD-2001 also features a rear compression system where the horn throat is built into the magnetic circuit, and the diaphragm is mounted from the rear, making use of the inside surface of the dome. The resonance generated at the edge is extremely small, and a very high degree of clarity has been obtained. Furthermore, by making the sound wave phase uniform at all frequencies, improved phase characteristics have been obtained, especially in the very high frequency range. The TD-2001 hence gives perfect coverage of all mid-range and high frequencies from 500Hz to 22,000Hz.

**Triple-Slit Phasing Plug**

One of the factors contributing to the superb frequency response is the triple-slit phasing plug engineered to an extremely high degree of precision (nominal deviation of  $\pm 0.02$ mm). Not only does this eliminate phase disturbances in the throat region, but also contributes to greater flatness of the frequency response.

**Power Magnetic Circuit with Magnetic Flux Density of 18,000G**

This powerful magnetic circuit employs a center pole and plate made of electro-magnetic iron inserted into a large 1kg alnico (Al.Ni.Co) magnet. Important improvements in magnetic efficiency have produced a total magnetic flux of 68,500Mx, and magnetic flux density of 18,000G possible, resulting in significant improvements in transient response and other speaker characteristics.

**Oxygen-Free Copper Short Ring Mounted on Center Pole**

In order to prevent deterioration in even minor characteristics which can result in the increase of impedance in the high frequency region, an oxygen-free copper ring has been mounted on the center pole of the magnetic circuit. Due to its excellent electrical conductance, oxygen-free copper reduces magnetic loss within the magnetic circuit to further smooth out the high end frequency response.

**Aluminum Edgewise Voice Coil**

By employing an aluminum edgewise voice coil covered with alumite insulating material, the conductor area in the electro-magnetic circuit is increased, thereby improving conversion efficiency. A heat-proof voice coil bobbin is also employed to improve stability and reliability.

## PRECAUTIONS

- Since this unit is quite heavy (14 lbs; 6.4kg) take extra care when handling.
- The horn must be mounted to the driver unit prior to applying any input signals. If signals are applied to the driver unit by itself, the diaphragm will be in danger of rupture when amplitude is increased, because in audio terms, the diaphragm is practically non-loaded (without the horn). Nor should signals be applied directly bypassing the crossover network (low-cut filter).
- When using a sine wave input signal to check operational sound, observe the following:—

When applied via crossover network

Use sine wave input signal of voltage below 2.8V (1W), and frequency above 600Hz.

When applied direct without crossover network

Use sine wave input signal of voltage below 0.9V (0.1W), and frequency above 100Hz.

## HORN MOUNTING

- Use a horn of 1in (25.4mm) throat diameter.
- Make the mounting pitch 3in (76.2mm) when only 2 mounting screws are used, and 2-1/4in (57.2mm) when 3 mounting screws are used.

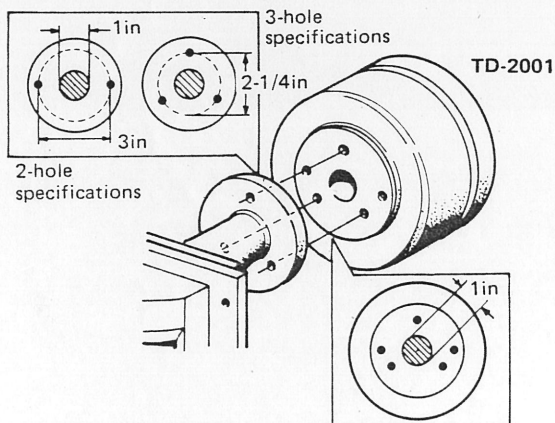

Use the accessory hexagonal screws (M6 × 15) and flat washers, making sure that each is secured firmly. Note that incorrect horn mounting may well result in deterioration of the frequency response, and the generation of distortion.

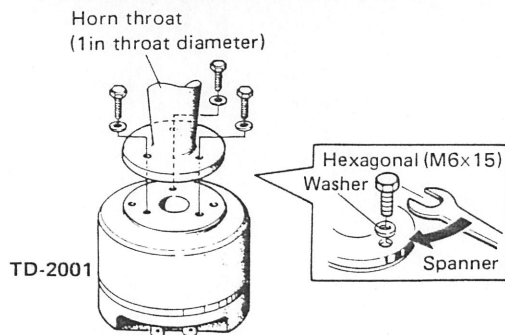

## CROSSOVER FREQUENCY AND MAXIMUM INPUT POWER

The crossover frequency of the TD-2001 is 800Hz. When using this unit in a multi-way speaker system, use a crossover frequency of 800Hz or higher, and a network of cut-off slope of at least 12dB/oct. These values are determined by the diaphragm vibration amplitude at maximum input. If networks of lower crossover frequencies are to be used, musical program input power will be decreased as shown in the following table.

Crossover Frequency (fc) : Hz	800	700	600
Musical Program input power : W	40	30	20

## Exploded Diagram of the TD-2001

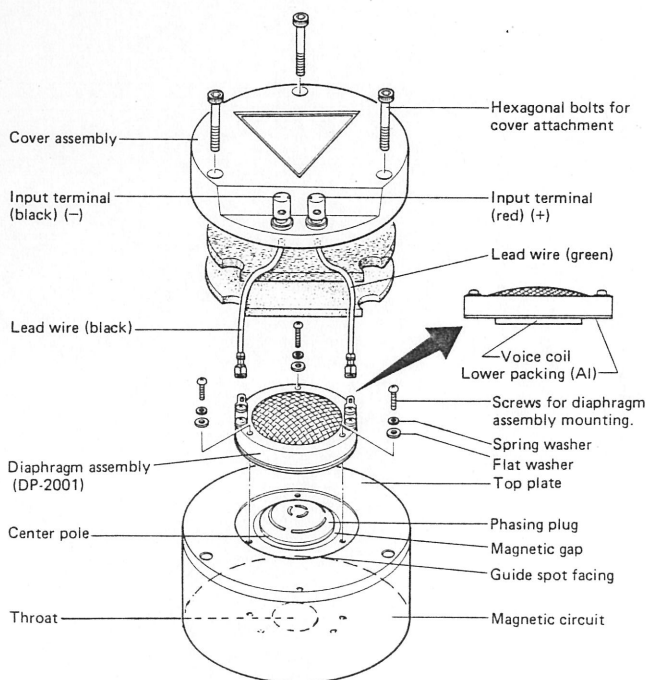

\* Replacement diaphragm assemblies (DP-2001) are also available.

**TAD** Technical Audio Devices

DIVISION OF U.S. PIONEER ELECTRONICS CORP.  
1925 E. Dominguez St., Long Beach, California 90810 U.S.A.

MANUFACTURER  
**PIONEER ELECTRONIC CORPORATION**  
4-1, Meguro 1-Chome, Meguro-ku, Tokyo 153, Japan