

HIGH FREQUENCY DRIVER

INSTRUCTION MANUAL

SPECIFICATIONS

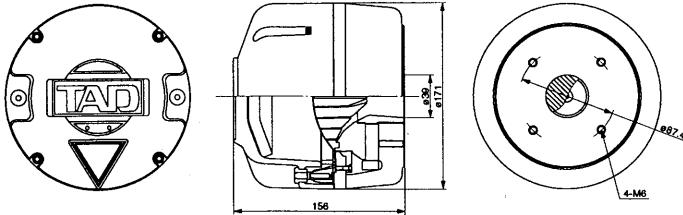

Nominal impedance	16 ohms
Frequency response	600 – 20,000 Hz (with suitable horn mounted)
Voice coil diameter	101 mm (4 in.)
Phasing plug	5-slit rear type
Throat connection diameter	39 mm (1-1/2 in.)
Mounting pitch	87.4 mm (3-7/16 in.) for 4 holes
Crossover frequency	600 Hz or higher (-12 dB/oct)
Rated input	30 W
Maximum input	60 W
Output sound pressure level	112 dB/W
(Measured at 1m distance using 400 Hz cut-off and dispersion angle 80° x 30° horn.)	
Total magnetic flux	228,000Mx
Magnetic flux density	20,000G
Dimensions (diam.x depth)	171 x 156 mm (6-4/3 x 6-1/8 in.)
Weight	9.9 kg (21 lb 12 oz)
Accessories	Hexagonal bolts M6 x 20 mm x 4 Flat washers x 4 Instruction manual x 1 Terminal tips x 2

NOTE:

Specifications and features are subject to change without notice due to improvements.

FEATURES

Pure Beryllium Diaphragm

The 100 mm diameter diaphragm is made of beryllium with an especially high quality, produced by special vacuum evaporation technology. As the extremely light and rigid beryllium has the highest speed of sound transfer of all metals, it is the ideal material for the membranes for high-frequency loudspeakers. For example, as the weight of the dome part is less than 1 g, the conversion efficiency in the high frequency range is extremely high, and as the edge part is made of the same beryllium as the dome part, the high-range is raised towards 20 kHz. Playback over the wide range from 600 Hz to 20,000 Hz is a notably wide range for a driver with a diameter of 100 mm.

Rear Compression System with a 1.5 Inch Throat

A rear compression system is used to solve the problems of surround resonance and phase distortion. By careful analysis of the cavity resonance at the edge part and in the magnetic circuit, it was possible to reduce parasitic resonance over the entire band and to obtain a rather flat frequency response. As the result, natural sound with an extremely high degree of definition is obtained.

The throat diameter has been made 1.5 inches. By combination with a 1.5-inch throat horn, the directivity has been improved. And the length of the throat under a high sound pressure could be shortened, thus reducing the occurrence of secondary harmonic distortion.

Newly Developed 5-slit Phasing Plug

The phasing plug with a new precision design has improved playback performance in the high frequency range because of precision phase matching from the circumference of the diaphragm. In addition, as the various sound passage shapes are not homogenous as in the case of a conventional phasing plug, the response is dispersed and natural sound is obtained, and a rather flat energy characteristic has been obtained by special measures for the sound passages. This phasing plug is made of high-strength aluminum diecast, so that the excess vibration level also is lowered and a still clearer sound is obtained.

Use of a Large Neodymium Equivalent Magnet

A neodymium magnet of $\phi 118 \times \phi 52 \times 12$ mm has been used because of the change to high magnetic flux density and the change to a 1.5-inch throat. In addition, the powerful internal magnetic circuit composed of a pure iron pole and top plate and a ductile cast iron yoke boasts of a total magnetic flux of 228,000 Mx and a magnetic flux density of 20,000 G. The oxygen-free copper shortening ring on the center pole prevents impedance increase in the high frequency range. As the result of the above, there is little distortion, and the frequency response has been extended to the extreme high-frequency range. The magnetic influence to the outside also is practically negligible.

New Construction for Back Cover and Input Terminals

The back cover made of thick-walled aluminum diecast has a double construction which prevents unwanted resonance by close examination of the shape, while also preventing acoustical resonance being fed back to the diaphragm movement. The input terminals have been changed from the conventional use of lead wires to a new construction with direct connection of the external lead wires to the diaphragm assembly, and the distortion voltage electromagnetically induced in the lead wires is eliminated. As the result, accurate playback without coloring can be executed down to minute input.

Aluminum Edgewise Voice Coil

Use of an aluminum edgewise voice coil with an alumite insulation coating and a voice coil bobbin made of 75 μ m thick polyamide film has increased the conductor volume in the magnetic gap widely and provides high efficiency and a still flat frequency response. The special adhesive with high heat resistance has positive stability and reliability.

PRECAUTIONS

- Since this unit is quite heavy 9.9 kg (21 lb 13 oz), take extra care when handling.
- The horn must be mounted to the driver unit prior to applying any input signals. If signals are applied to the driver unit by itself, the diaphragm will be in danger of rupture when amplitude is increased, because in audio terms, the diaphragm is practically non-loaded (without the horn). Nor should signals be applied directly bypassing the crossover network (low-cut filter).
- When using a sine wave input signal to check operational sound, observe the following:
When applied via crossover network
Use sine wave input signal of voltages below 4 V and frequencies above 600 Hz.
When applied directly without crossover network
Use a sine wave input signal of voltages below 2 V and frequencies above 200 Hz.

CONNECTIONS:

Solder the accessory terminal tips to speaker cable and connect by inserting ⊕ into the red hole and ⊖ into the black hole.

HORN MOUNTING

- Use a horn throat diameter of 38.1 mm (1-1/2 in.) – 39.7 mm (1-9/16 in.)
- Make the mounting pitch 87.4 mm (3-7/16 in.) using the 4 mounting screws supplied.

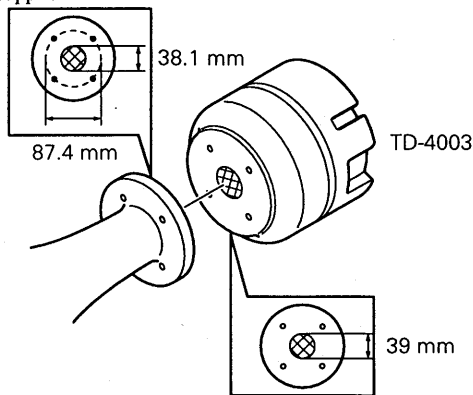

Use the accessory hexagonal screws (M6 x 20) and flat washers, making sure that each is secured firmly. Note that incorrect horn mounting may well result in deterioration of the frequency response, and the generation of distortion. For a horn flange of less than 4 mm (5/32 in.) in thickness, the screws furnished with the unit cannot be used; use commercially available M6 screws.

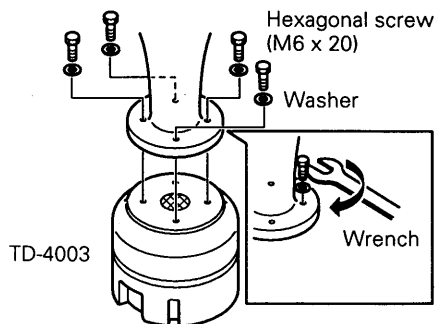

CROSSOVER FREQUENCY

The crossover frequency of the TD-4003 is 600 Hz. When using this unit in a multi-way speaker system, use a cross-over frequency of 600 Hz or higher, and a network of cut-off slope of at least 12 dB/oct.

Exploded Diagram of the TD-4003

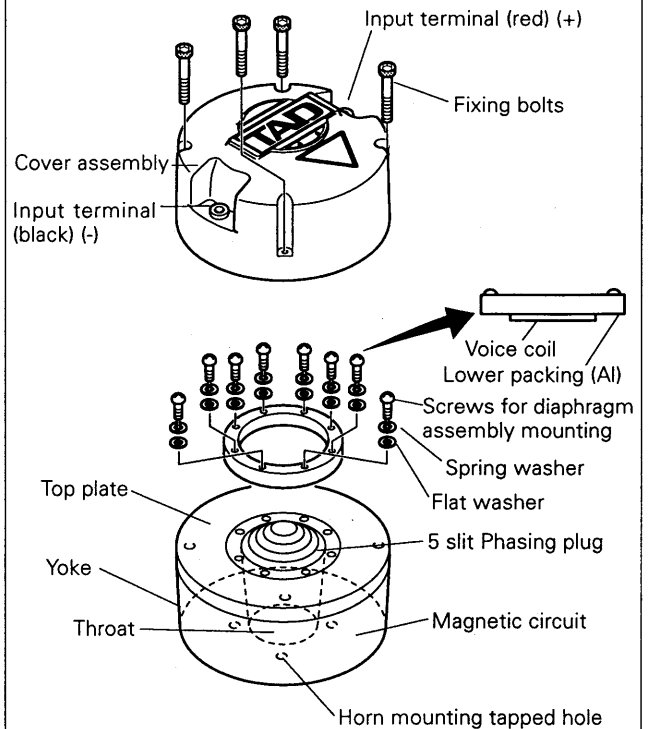

* Replacement diaphragm assemblies SXV1004 are also available.

Cautions at the Time of Diaphragm Assembly Exchange

- At the time of cover removal, pull out all mounting hexagonal bolts.
- The cover can be removed by inserting a flat screwdriver etc. at the part where its side is in contact with the top plate.
- The diaphragm assembly has no protective net. Accordingly, take care not to drop objects or the mounting bolts onto the diaphragm after removal of the cover, as this can cause breakage.
- Use a cross-slot screwdriver with a non-magnetic bit for removal and installation of the diaphragm assembly. Otherwise, the screwdriver may be pulled by the magnetic force and may damage the diaphragm assembly. Use special caution during screw removal and installation.
- At the time of installation of the diaphragm assembly, special care is required to prevent contact of the voice coil with the magnetic circuit, as this can cause faulty operation. Tighten all mounting screws with equal force.
- Install the cover with correct directionality for diaphragm mounting ring and cover.

Published by Pioneer Electronic Corporation.
Copyright © 1997 Pioneer Electronic Corporation.
All rights reserved.

TAD Technical Audio Devices

PIONEER ELECTRONIC CORPORATION 4-1, Meguro 1-Chome, Meguro-ku, Tokyo 153, Japan
PIONEER ELECTRONICS SERVICE, INC. P.O. Box 1760, Long Beach, CA 90801-1760, U.S.A.
PIONEER ELECTRONIC [EUROPE] N.V. Haven 1087 Keetberglaan 1, 9120 Melsele, Belgium