

LOW FREQUENCY LOUDSPEAKER

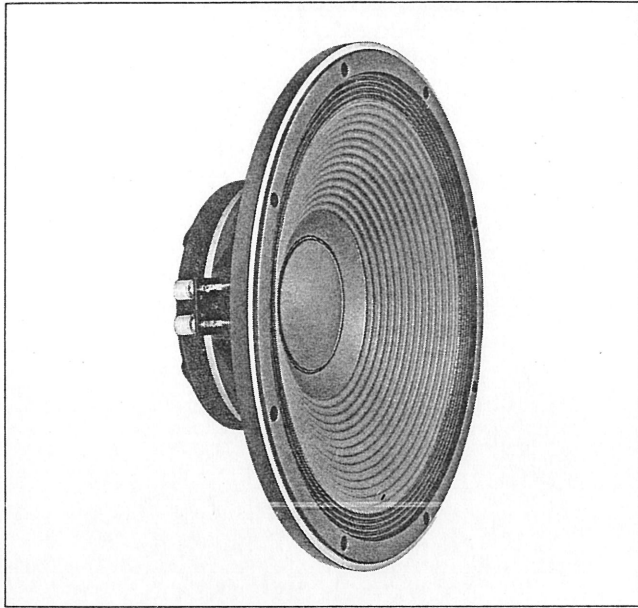

FEATURES

500W maximum permissible input, with high acoustic efficiency

The TL-1603 features an edgewise-wound 7/8 in (23mm) long-travel voice coil which moves completely within the magnetic gap even at peak-to-peak excursions as long as 5/8 in (16mm). You are thus assured of powerful, distortion-free bass at virtually all input levels. The edgewise conductors make more effective use of the flux within the magnetic gap, resulting in increased acoustic conversion efficiency. The voice coil bobbin and adhesive materials are extremely heat resistant resulting in a maximum input of 500W.

Low-distortion high-efficiency magnetic circuit

The powerful magnetic circuit of the TL-1603 is equipped with ferrite magnet to ensure highly stable operation at high power. Great care has been taken in the selection of the material and shape of the poles to produce an extremely high flux density of 11,800G. This, in combination with lighter moving parts and the long-travel voice coil have resulted in a sensitivity of 97dB/W (1m), an excellent figure in consideration of the size of this speaker.

Newly developed cone

The cone of the TL-1603 is made of a newly developed tough, lightweight material, capable of withstanding high amplitude inputs. It features high internal loss and ideal corrugations, resulting in a smooth response right down to the extreme end of the bass region.

Use of corrugation type cloth surround

The TL-1603 employs an extremely linear corrugation type cloth surround which has been coated with a specially developed damping material to provide a sufficient degree of internal loss. This ensures positive piston action at high amplitude and also prevents cone breakup in the higher region, resulting in extremely low distortion.

SPECIFICATIONS

Voice coil impedance	8Ω
Fundamental resonance (f_0)	28Hz
Frequency response	$f_0 \sim 1,000\text{Hz}$
Rated input	200W
Maximum input	500W
Output sound pressure level	97dB/W (1m)
Equivalent mass (infinite baffle)	117g
Q_0	0.31 ($f_0 = 28\text{Hz}$)
Total magnetic flux	260,000Mx
Flux density	11,800G
External dimensions	15-3/4 in (400mm) diam., 5-5/6 in (148mm) depth
Baffle opening	13-7/8 in (352mm) diam.
Mounting dimensions	14-9/16 in (370mm) diam.
Weight	9.5kg
Accessories	Mounting screws (M5x40 Phillips head); 8 Nuts, fang nuts, washers; 8 each Airtight packing; 4 Instruction manual; 1

• Specifications and dimensions are subject to change without notification.

Strong diecast frame

The TL-1603 employs a sturdy aluminium alloy diecast frame which firmly supports the extremely heavy magnetic circuit and also the highly efficient moving parts of the speaker. The frame itself has been designed in such a way that it does not resonate.

HARMONIC DISTORTION DIRECTIONAL FREQUENCY RESPONSE

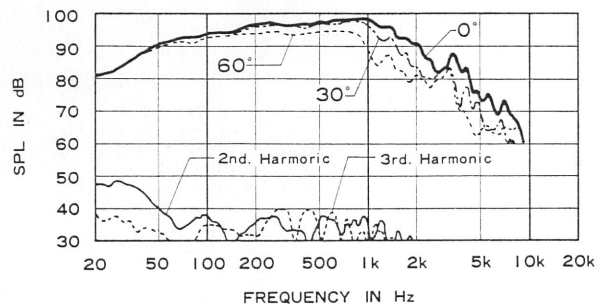

IMPEDANCE

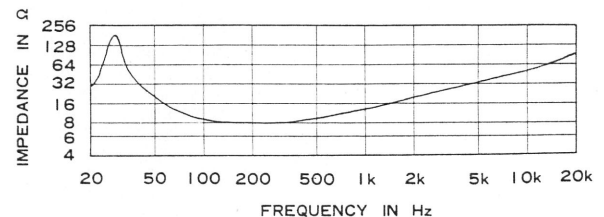

CROSSOVER FREQUENCY

It is recommended that the TL-1603 be used with a crossover network (low-pass filter) having a crossover frequency of no more than 900Hz, and cutoff characteristics of either 12dB/oct or 18dB/oct.

When a high-range impedance compensation network is necessary, insert $20\mu\text{F} + 8\Omega$ in parallel with the speaker.

Method of fitting gasket

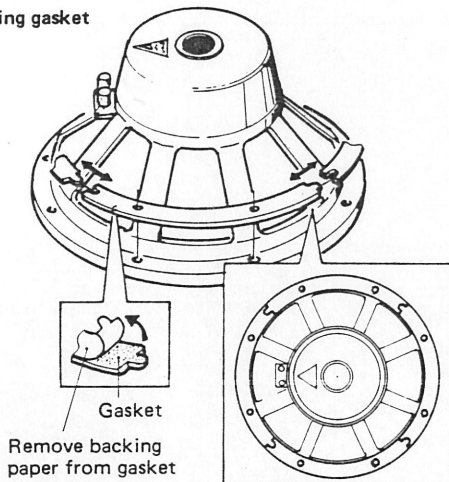
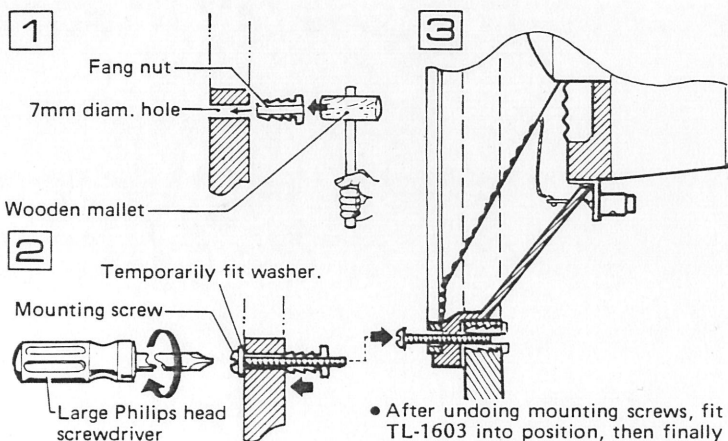

Fig. 1

INSTALLATION METHOD

WHEN USING FANG NUTS

First, drill 7mm diam. holes in the baffle. Next, using the method shown in Fig. 2, drive fang nut into these holes from the back of the baffle. Finally, insert the screws provided (8) and tighten them up.



- Use screwdriver to pull fang nut completely into baffle board.

- After undoing mounting screws, fit TL-1603 into position, then finally reinsert screws and tighten securely. Progressively tighten up diagonally opposite screws, applying final tightening torque after adjusting position of speaker. As washers are not required, make sure they are removed from the mounting screws.

Fig. 2

Exploded TL-1603

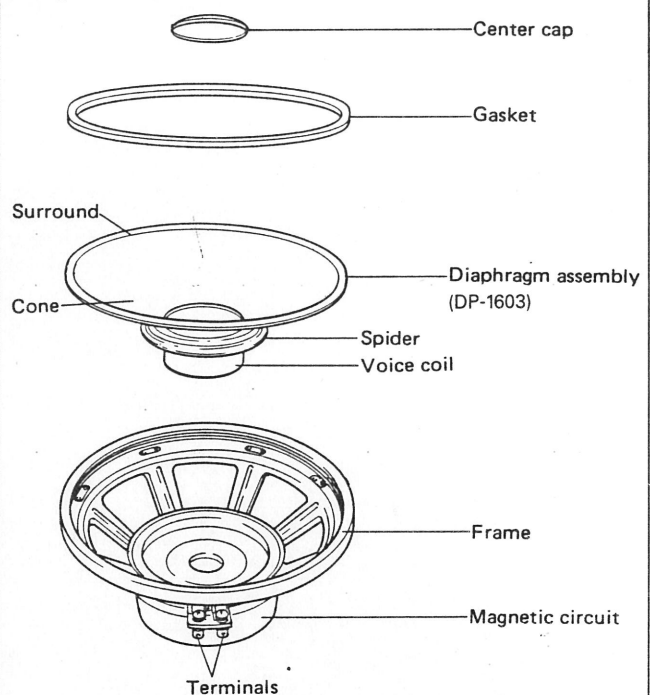

* Replacement diaphragm assemblies (DP-1603) are also available.

WHEN USING NUTS

First, drill 6mm diam. holes. Next, using the method shown in Fig. 3, fit mounting screws, washers and nuts, and then tighten up firmly.

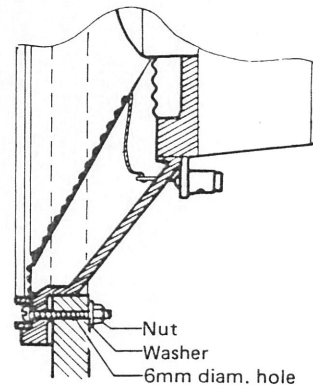

Fig. 3

Note:
Be careful not to short-circuit the cable end when hooking up.

TAD Technical Audio Devices